



Gate valve



Globe valve



Check valve



Ball valves

online
Communication 

Contact Us

WENZHOU WINDMILL VALVE CO.,LTD.
ADD:OuBei,WenZhou,Zhejiang,China
TEL:86-577-67955569
FAX:86-577-67955565
E-Mail:sale@dfcvalve.com

Steel Gate valve

Steel Gate valves

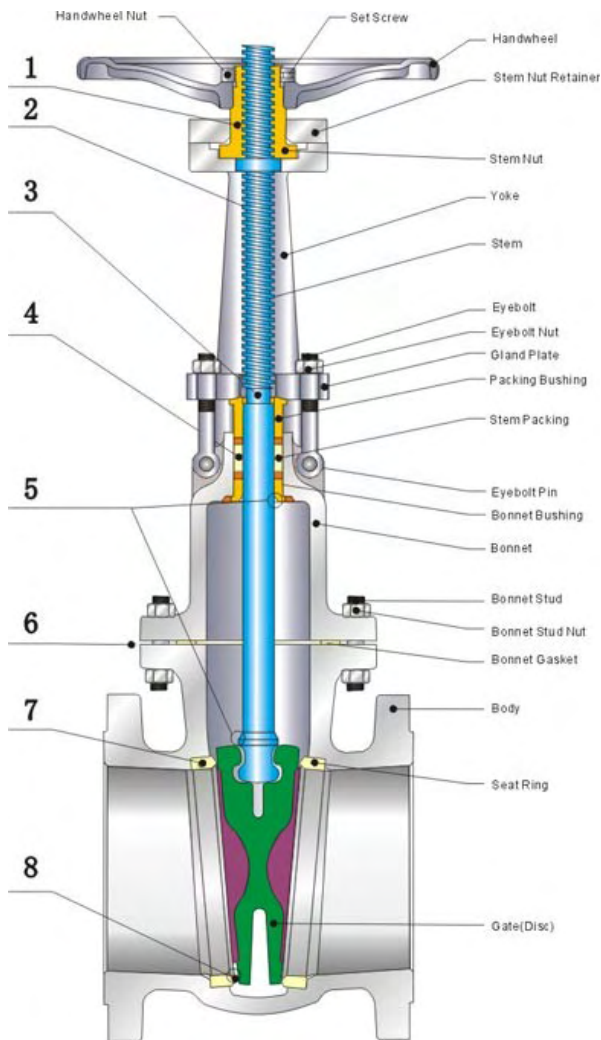

- 1 - Gate valve Stem Nut, replaceable in line.
- 2 - Steel Gate valve Rising stem with precision ASME double thread for quick operation.
- 3 - Stem-Gate connection designed so that under severe applied loads(stuck gate), the stem will fail outside of the stuffing box pressure boundary.
- 4 - Stem Packing is designed for optimum control of fugitive emissions leakage to the atmosphere. The ultra-low emission leakage rate is assured by the fine finish on the stem sealing area, the reduced diametrical clearances and the stem straightness control.
- 5 - Backseat, designed to relieve back pressure on the stem packing when fully seated. Replacing stem packing under pressure is not recommended.
- 6 - Body to Bonnet joint designed to apply a uniform load to the gasket to assure a leak proof seal.
- 7 - Steel Gate valve Seat rings are seal welded to provide a bubble tight joint.

PRODUCT CATALOG

- [About us](#)
- [Products](#)
- [Gate valves](#)
- [Globe valve](#)
- [Check valve](#)
- [Ball valves](#)
- [Butterfly valve](#)
- [Plug valves](#)
- [Forged valve](#)
- [Bronze Valve](#)
- [Strainer](#)
- [News](#)

ABOUT PRODUCTS

- [Steel valves](#)
- [Valve News »](#)

NEW PRODUCT